

# CLUSTER 3-PERSON UPHOLSTERED BENCH

COD.OCLUS301



## DESCRIPTION

3-person bench with upholstered seat and backrest

## NOTE

Accessories: Armrest; Table for seat substitution; Fixed legs.

11M fire retardant B01 fabric upholstered shell 

UNI EN 1022, 1728, 15373, 13761 

## TECHNICAL INFORMATION

### STRUCTURE

Aluminum finished steel frame 1,2mm; Upholstered seat and backrest with internal wooden panel

### PADDING

Seat: thickness 20 mm, density 40 Kg/m<sup>3</sup>

Backrest: thickness 15 mm, density 30 Kg/m<sup>3</sup>

### ARMS

Aluminum finished steel

### LEGS / FRAME / BASE

Steel tube legs 90x30x1,5 with aluminum finish

Steel tube beam 80x40x1,5 with aluminum finish

### UPHOLSTERY

categories B01-B03-C0-C04 (SEE FABRIC FOLDER)

## DIMENSION

bench  
L 2030 H 860 D 670

seat  
L 490 H 440 D 440

backrest  
L 490 H 475

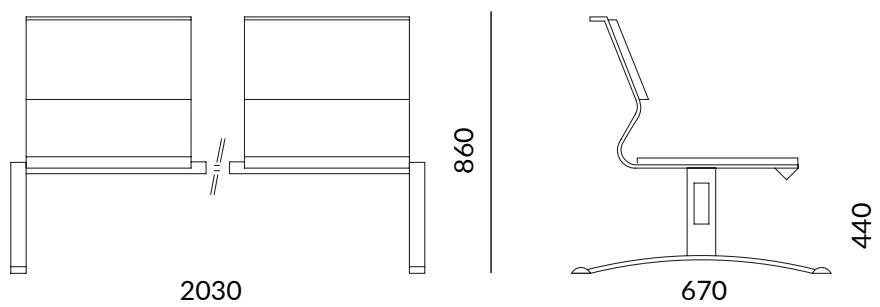

### WEIGHT

Net weight: 45 Kg  
Gross weight: 48 Kg

### PACKAGING

2 packages

### VOLUME

M3 box: 0,4

COD.OCLUS301

TECHNICAL  
DATASHEET

Dimensions in millimeters

The Quadrifoglio Group

Quadrifoglio  
OFFICE FURNITURE

OFFICITY  
BUSINESS SPACE

OFFST

karboxx

nyx  
by karboxx

offisit.com